

**B.5000**

Bremse  
brake

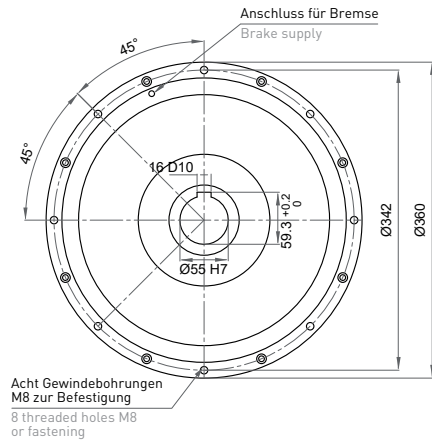

**B.5000.R**

Bremse mit Radiator  
brake with radiator

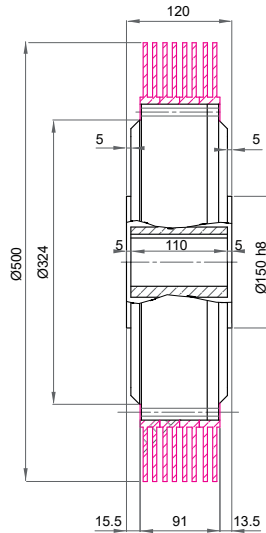

**B.5000.V**

Bremse mit Lüfter  
brake with fan

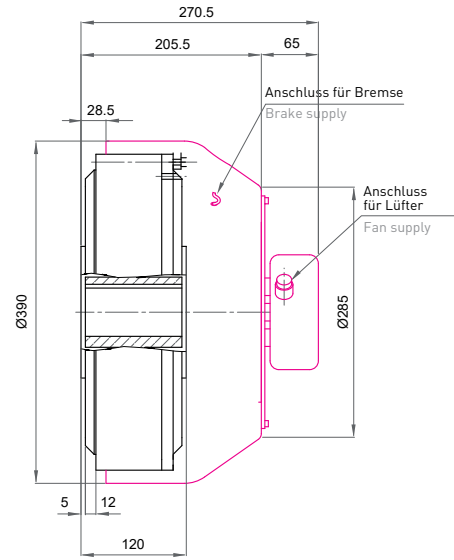

**C.5000**

Kupplung  
clutch

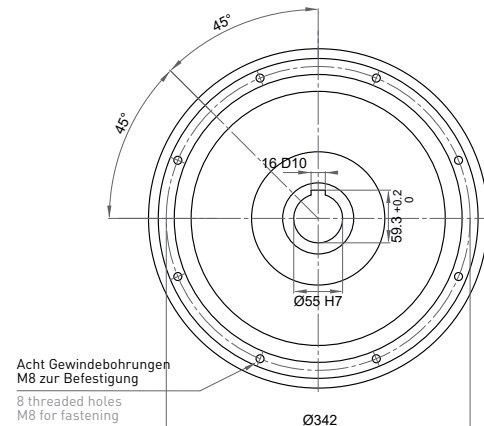
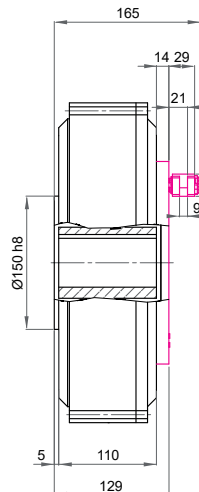
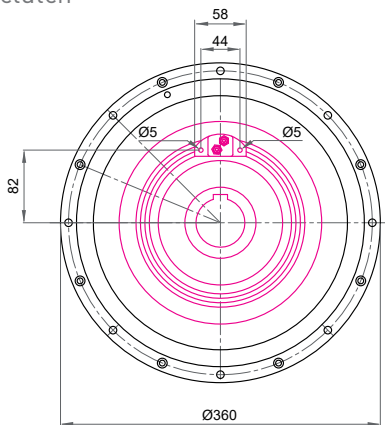

Max. Drehmoment / Max. torque	500 Nm
Restdrehmoment / Residual torque	6 Nm
Max. Stromaufnahme / Max. current	0,94 A
Widerstand / Resistance	25,5 Ohm
Spannung / Supply Voltage	24 V (PWM)
Wärmeableitung / Power dissipation	1300 W
Wärmeableitung mit Radiator / Power dissipation with radiator	2500 W
Wärmeableitung mit Lüfter / Power dissipation with fan	4000 W
Wärmeableitung der Kupplung bei 500 U/min. / Power dissipation of the clutch at 500 RPM	2800 W
mit Radiator bei 500 U/min. / with radiator at 500 RPM	4000 W
Wärmeableitung der Kupplung bei 1000 U/min. / Power dissipation of the clutch at 1000 RPM	3500 W
mit Radiator bei 1000 U/min. / with radiator at 1000 RPM	5000 W
U/min. min.-max. / RPM min-max	40-1500
Max. Arbeitstemperatur / Max. working temperature	70 °C
Gewicht kg / Weight kg	59 (B.5000) / 62 (B.5000.R) / 62 (B.5000.V) 62 (C.5000) / 65 (C.5000.R)

